

Iowa Site Inventory Form

State Historic Preservation Office

(January 2016)

State Inventory Number: 44-00259 New Supplemental

9-Digit SHPO Review & Compliance (R&C) Number: _____

Non-extant Year: _____

Read the Iowa Site Inventory Form Instructions carefully, to ensure accuracy and completeness before completing this form. The instructions are available on our website.

• Property Name

A) Historic name: J.F. Sargent House / D.L. Cookes Funeral Home

B) Other names: 2023 downtown survey # DT-082

• Location

A) Street address: 213 N. Main St

B) City or town: Mount Pleasant (Vicinity) County: Henry

C) Legal description:

Rural: Township Name: _____ Township No.: _____ Range No.: _____ Section: _____ Quarter: _____ of Quarter: _____

Urban: Subdivision: Original Block(s): 19 Lot(s): 5

• Classification

A) Property category: *Check only one*

- Building(s)
- District
- Site
- Structure
- Object

B) Number of resources (within property):

<i>If eligible property, enter number of:</i>		<i>If non-eligible property, enter number of:</i>	
<u>Contributing</u>	<u>Noncontributing</u>		
<u>2</u>	Buildings	<u>—</u>	Buildings
<u>—</u>	Sites	<u>—</u>	Sites
<u>—</u>	Structures	<u>—</u>	Structures
<u>—</u>	Objects	<u>—</u>	Objects
<u>2</u>	Total	<u>—</u>	Total

C) For properties listed in the National Register:

National Register status: Listed De-listed NHL NPS DOE

D) For properties within a historic district:

- Property contributes to a National Register or local certified historic district.
- Property contributes to a potential historic district, based on professional historic/architectural survey and evaluation.
- Property *does not* contribute to the historic district in which it is located.

Historic district name: Mt Pleasant Downtown Historic District Historic district site inventory number: 44-02280

E) Name of related project report or multiple property study, if applicable:

MPD title

Historical Architectural Data Base #

Intensive Level Historical and Architectural Survey of Downtown Mt Pleasant, Iowa

HADB-02986

• Function or Use *Enter categories (codes and terms) from the Iowa Site Inventory Form Instructions*

A) Historic functions

01: DOMESTIC / single dwelling

07C02: FUNERARY / funeral home

B) Current functions

07C02: FUNERARY / funeral home

• Description *Enter categories (codes and terms) from the Iowa Site Inventory Form Instructions*

A) Architectural classification

05B: Late Victorian / Italianate

B) Materials

Foundation (visible exterior): 04C: Limestone

Walls (visible exterior): 03: Brick

Roof: 08A: Asphalt shingle

Other: _____

C) Narrative description **SEE CONTINUATION SHEETS, WHICH MUST BE COMPLETED**

Site Number: 44-00259 Address: 213 N. Main St City: Mt Pleasant County: IA District Number: 44-02280

• **Statement of Significance**

A) Applicable National Register Criteria: *Mark your opinion of eligibility after applying relevant National Register criteria*

- Criterion A: Property is associated with significant events. Yes No More research recommended
Criterion B: Property is associated with the lives of significant persons. Yes No More research recommended
Criterion C: Property has distinctive architectural characteristics. Yes No More research recommended
Criterion D: Property yields significant information in archaeology/history. Yes No More research recommended

B) Special criteria considerations: *Mark any special considerations; leave blank if none*

- A: Owned by a religious institution or used for religious purposes. E: A reconstructed building, object, or structure.
 B: Removed from its original location. F: A commemorative property.
 C: A birthplace or grave. G: Property less than 50 years of age or
 D: A cemetery achieved significance within the past 50 years.

C) Areas of significance

Enter categories from instructions

05: Commerce

02: Architecture

D) Period(s) of significance

E) Significant dates

Construction date

1866 *check if circa or estimated date*

Other dates, including renovations

1935, 1963

F) Significant person

Complete if Criterion B is marked above

G) Cultural affiliation

Complete if Criterion D is marked above

H) Architect/Builder

Architect

Builder/contractor

I) Narrative statement of significance **SEE CONTINUATION SHEETS, WHICH MUST BE COMPLETED**

• **Bibliography** *See continuation sheets for the list research sources used in preparing this form*

• **Geographic Data** *Optional UTM references* *See continuation sheet for additional UTM or comments*

Zone	Easting	Northing	NAD	Zone	Easting	Northing	NAD
1				2			
3				4			

• **Form Preparation**

Name and Title: Rebecca Lawin McCarley / research by Barb Welander & Pat White Date: April 10, 2024

Organization/firm: SPARK Consulting / Mt Pleasant HPC E-mail: sparkconsulting@octaspark.com

Street address: 1630 Park Ave SE Telephone: 319-200-9767

City or Town: Cedar Rapids State: IA Zip code: 52403

• **ADDITIONAL DOCUMENTATION** *Submit the following items with the completed form*

A) For all properties, attach the following, as specified in the Iowa Site Inventory Form Instructions:

- 1. Map** of property's location within the community.
- 2. Glossy color 4x6 photos labeled** on back with property/building name, address, date taken, view shown, and unique photo number.
- 3. Photo key showing each photo number on a map and/or floor plan, using arrows next to each photo number to indicate the location and directional view of each photograph.**
- 4. Site plan** of buildings/structures on site, identifying boundaries, public roads, and building/structure footprints.

B) For State Historic Tax Credit Part 1 Applications, historic districts and farmsteads, and barns:

See lists of special requirements and attachments in the Iowa Site Inventory Form Instructions.

State Historic Preservation Office (SHPO) Use Only Below This Line

The SHPO has reviewed the Site Inventory and concurs with above survey opinion on National Register eligibility:

- Yes No More research recommended
 This is a locally designated property or part of a locally designated district.

Comments: _____

SHPO authorized signature: _____ Date: _____

Iowa Site Inventory Form
State Historic Preservation Office
Continuation Sheet

Site Number: 44-00259
Related District Number: 44-02280

Page 1

J.F. Sargent House / D.L. Cookes Funeral Home	Henry
Name of Property	County
213 N. Main St	Mount Pleasant
Address	City

7. Narrative Description

This is a two-story brick residence designed in the Italian Villa style with a prominent front square tower. The house was completed in 1866 for the Sargent family, sold to the Worthington family in 1901, and converted for use as a funeral home in 1935. The brick house sits on a stone foundation, and the hip roof has asphalt shingles.

The house faces N. Main St to the east. The current front porches and entry hood date to the early 1900s while the Worthingtons lived here, replacing an earlier entry porch and porch on the south portion of the façade. The double-door entry with arch transom is set into a rectangular opening with the entry hood and pilasters. The entry is in the base of the square tower, which has a wide cornice with decorative bracket and wide eaves, typical of the Italian Villa style. The tower section has an eight-light arch window on the second story with a decorative hood similar to the entry hood, and it has an eight-light arch window on the third story, with a limestone band at the sill level. The north portion of the east/front elevation has two arch windows on each story. The first story has tall four-over-four-light double arch wood windows behind eight-light storm windows, and the second story has regular size four-over-four-light double-hung wood windows that have a wider vertical muntin. The wide eaves of the house have a wide wood frieze and decorative brackets. The south portion appears to be an early addition. It appears on the 1886 Sanborn map so it was constructed prior to this date. It balances the north portion with arch openings on each story. One of the first story openings has an entry that leads out to the porch, and the second one is six-light wood window with two-light arch transom. The second story appears to have a two-over-four-light double-hung window with a two-light arch transom and a six-light wood window with a two-light arch transom. The arch windows on the east/front of the house have slightly projected brick hoods with brackets/corbels, and they have stone sills. The wide eaves of the house have a wide wood frieze and decorative brackets that are smaller and simpler than the north portion.

The north side elevation consists of the side of the original two-story house, side of a one-story side addition, and side of the rear addition. The north elevation of the original house has a five-sided bay window on the first story with a flared hip roof and small brackets. Three of the sides have three-light wood arch windows. The first story window to the right/west of the bay window and the two second story windows match the windows on the front of this portion of the house. The large scroll brackets under the wide eaves continue around this portion of the house and around the west/rear side. A partially engaged brick chimney is centered between the windows on each story, and it has had the top removed. The one-story shed-roof brick addition at the edge of the rear portion of the original house and across most of the rear section was constructed in 1937 soon after the conversion to a funeral home, and it appears on the 1942 Sanborn map. The north side has a centered side entry with a small curved entry hood with brackets. A two-over-two-light double-hung wood window with a segmental brick arch lintel and stone sill is found to either side of the entry. A four-over-four-light double-hung wood window that has a wider vertical muntin is found on the north side of the original rear section to the west/rear of the one-story side addition. This segmental arch window has a brick hood and stone sill. The rear section of the house was originally one story (kitchen section), with the second story added in the early 1900s by the Worthington family (one story on the 1899 map, two story on the 1909 map). This section has small brackets under the eaves, which are not as wide as the main section of the house. The north side of the second story has three windows that have segmental arch brick hoods and stone sills that match the first story window. The center window is smaller/higher (likely associated with a bathroom), and it has one-

Iowa Site Inventory Form
State Historic Preservation Office
Continuation Sheet

Site Number: 44-00259
Related District Number: 44-02280

Page 2

J.F. Sargent House / D.L. Cookes Funeral Home	Henry
Name of Property	County
213 N. Main St	Mount Pleasant
Address	City

over-one-light double-hung sashes. The windows to either side have two-over-two-light double-hung wood sashes. The garage addition extends further to the rear/west of the rear section of the house.

The south side elevation of the house likewise consists of distinct components. The front/east portion of the south elevation is the side of the early two-story brick addition, and this side wing is narrower than the north side of the original house. The first story has a five-sided bay window with three arch windows that matches the bay window on the north side. The second story has a two-over-two-light double-hung wood arch window with brick arch hood. The additions on the side of the two-story rear section of the house do not appear on the 1942 Sanborn map, which showed a porch along this side of the rear section. The front/east addition is a one-story brick shed-roof addition with no openings, and the rear/west addition on the south side of the rear section is a two-story frame shed-roof addition with vinyl siding constructed in 1963. It has three one-over-one-light double-hung windows on each story on the south side. The west/rear side of the frame addition has a rear entry and double-hung window on the first story and wood steps that lead to a wood deck and rear entry on the second story.

The original west/rear elevation of the rear section of the house is only visible on the second story, which would be the portion added in the early 1900s. The small brackets continue on this side, and the second story has a two-over-two-light double-hung segmental arch window. The garage addition then extends to the rear of the brick house. This original tile block addition was added in 1937 soon after the conversion to a funeral home, shown on the 1942 Sanborn map and noted for 4 cars. The openings on the north side of the garage have been modified for two wider garage doors than were likely originally on this side, with the remainder of the north side clad in vertical wood siding. A later concrete block rear addition was built likely in the 1960s on the west/rear of the garage section, extending the building to near the alley. The north side has a wide entry.

The 1942 Sanborn map shows a long frame garage along the alley. This garage appears to have been moved to the south part of the lot and rotated by 90 degrees, likely at the time of the final rear addition. This garage sits on a concrete foundation, and the hip roof is clad in asphalt shingles. The frame walls are clad in wide wood siding, which appears to be installed over vertical wood siding. There is an overhead garage door on the west side facing the alley, and a pedestrian door on the north side.

8. Narrative Statement of Significance

The J.F. Sargent House / D.L. Cookes Funeral Home appears to be eligible for listing on the National Register of Historic Places as a contributing building within the potential Mount Pleasant Downtown Historic District. Commercial development extended north on the 200 block of N. Main Street by the early 20th century, with some houses remaining interspersed on the block. This large house was part of the early residential development of the block, and it became the location of D.L. Cookes Funeral Home in 1935. The move of the undertaker from a commercial building one block to the south reflects the trend in this period of undertakers to move to large residences, which were then funeral homes. The building has remained a funeral home on the north edge of downtown since 1935. The building retains sufficient integrity to convey its significance as a historic building in a historic district.

Based on research and evaluation conducted to date, this building appears to be potentially individually eligible for listing on the National Register of Historic Places under Criterion C for its Italianate architecture

Iowa Site Inventory Form
State Historic Preservation Office
Continuation Sheet

Site Number: 44-00259
Related District Number: 44-02280

Page 3

J.F. Sargent House / D.L. Cookes Funeral Home	Henry
Name of Property	County
213 N. Main St	Mount Pleasant
Address	City

and under Criterion A for its association with the funeral home. Further research and assessment of the interior features and modifications would be required for a full evaluation of the individual eligibility of the building.

Developmental history of property

The 2-story, brick Italianate house at 213 North Main Street was built over several years from 1862 to 1866. The house was later converted into a funeral home in 1935.

William Brown is the first individual shown to own lot 5 of block 19 in the transfer books. J.F. Sargent (1829-March 1899) is shown to later own the same property. It is not noted how or when either of these men acquired this lot (Transfer Book "A", page 20). The house was constructed by J.F. Sargent

The *Biographical review of Henry County, Iowa* (1906) includes a biography of James Franklin Sargent, which notes: "In 1864, he built a fine brick residence on North Main street, where he lived until his death" (page 262). Sargent was born in New Hampshire in 1829, learning the jeweler's trade in Massachusetts, worked as a jeweler in Utica, New York, and moved to Mt Pleasant in 1855 upon hearing that the town lacked a jeweler. He started on the west side of the square and then moved to the northwest corner of the square. He then moved in 1875 to a building that he had purchased on the north side of the square (125 W. Monroe), where he remained until he retired around 1887. He was recognized as one of the leading merchants of the city, with a large stock of goods. His first wife died, and he remarried in 1880 to Emma Kelson. They had a daughter, Birdie Eleanora Sargent. James F. Sargent died on March 27, 1899. Following the death of her husband, Mrs. Sargent sold the large house and built a pleasant residence on W. Monroe St (page 262-263).

The newspaper notes in July 1865: "IMPROVEMENTS – Notwithstanding the high price of material and labor, considerable improvement is going on in our city. Mr. J.F. Sargent has commenced work on a new residence which he is going to build on the corner of Main and Henry Streets. This will be one of the finest, if not the finest, residence in the city". (*The Home Journal*, July 14, 1865, page 3)

Excerpts from page 27, *Victorian Period Home Architecture-Mt. Pleasant*, by Melba Rae Widmer (1989): "The eighteen-inch foundation of Bedford stone was installed in 1862. After allowing it to settle for two years, construction was begun in the summer of 1864, and finished in 1866, by W.L. Murphy, contractor... The walls above the foundation are constructed of solid brick, fourteen-inches thick, except for two bays. The door and window openings were cut and the frames fit to them, because there was not a square plumb opening in the original structure. Three rooms have been added, but no changes have been made to the original structure, because all of the interior walls are weight-bearing, brick walls."

James F. Sargent married Sarah Mailing in 1866, as the house was completed. The house is clearly depicted on the 1869 birds-eye view of Mt Pleasant. The couple did not have any children, and Sarah died in 1879 at the house on N. Main. J.F. Sargent (age 50, widowed) is enumerated in the 1880 census of Mount Pleasant, Henry County, Iowa. Jewelry/book store is his profession, and his street address is North Main, with no specific house number given. He remarried in 1880 to Emma Kelson. They had a daughter, Birdie Eleanora Sargent. The 1885 Iowa census lists James F. Sargent (age 50) with his new

Iowa Site Inventory Form
State Historic Preservation Office
Continuation Sheet

Site Number: 44-00259
Related District Number: 44-02280

Page 4

J.F. Sargent House / D.L. Cookes Funeral Home	Henry
Name of Property	County
213 N. Main St	Mount Pleasant
Address	City

wife Emma (age 28) and young daughter, Birdie. J.F. Sargent operates a jewelry store, and the family resides on N Main.

The 1886 Sanborn fire insurance map shows a 2-story, brick dwelling at the southwest corner of Henry and Main, with frame, bay windows on the north and south sides. A 1-story, brick addition is attached to the west, with a 1-story, open frame porch on the south side. A 3-story, brick tower is on the east entryway, with a 1-story, open frame porch. A small, brick shed is by the alley. The address is 431 Main.

The 1892 Sanborn fire insurance map shows the same footprint for this dwelling as the previous map. The building front faces to the east. The address is 431 N Main and 213 N Main.

The 1893 Mount Pleasant City Directory shows J.F. Sargent, retired, residence 213 N Main. James F. Sargent (age 63, married) is enumerated in the 1895 census of Mount Pleasant, Henry County, Iowa, with wife Emma Sargent, though no address is shown. The 1899 Sanborn fire insurance map shows the same footprint for this building as previous maps. There is now a small, 1-story frame shed to the west of the building and a small, 1-story brick shed farther to the west, by the alley. The address is 213 N Main. James F. Sargent died on March 27, 1899. Emma Sargent (age 46, widow) is enumerated in the 1900 census of Mount Pleasant, Henry County, Iowa. The address of her residence is 213 North Main.

On 1 October 1901, Emma K. Sargent (1853-1934) sells lot 5 of block 19 to Belle C. Worthington for \$4,000 (Transfer Book "B", page 18). The 1905 Iowa Census lists W.D. Worthington and his wife Belle C. living at 215 N. Main St. The 1909 Sanborn fire insurance map shows the addition to the west of the building is now a 2-story brick addition. On the east/front side of the dwelling, the 1-story, frame porch has been enlarged and another, small, 1-story, frame porch has been added. There is now a 1-story, frame structure (likely garage) on the northwest corner of the property, facing W Henry. The address of the dwelling is 215 N Main and 213 N Main. The 1910 census lists William Worthington (53) as a bookkeeper at a bank and wife Belle (53) as a piano teacher. The 1911-1912 Henry County Directory lists Wm. D. Worthington and wife, Belle C. Worthington living at 215 N Main. The 1920 Sanborn fire insurance map shows the same footprint for this dwelling as the previous map. The address of the dwelling is 215 N Main. There is now a 1 ½ story, frame garage on the northwest corner of the property, with a front and rear section noted. The 1920 federal census lists W.D. and Belle C. Worthington at 215 N Main. W.D. is a 62-year-old bookkeeper at bank, and Belle C. is a 62-year-old music teacher at home. William D. Worthington died on December 26, 1924.

The 1925 Iowa census lists Belle C. Worthington (widow) continuing to live at 215 N Main, with her sister, Flora C. Dillon. They remain here until the death of Belle on November 4, 1933. On 4 December 1933, the Belle C. Worthington Estate transfers the property "By Will" to Flora C. Dillon (Transfer Book "1", page 22; Will Record "G"/575). Flora C. Dillon then died on March 27, 1935. On 21 June 1935, Belle C. Swain, et al, heirs of Flora C. Dillon, sell the property to Dan L. and Nellie M. Cookes for \$3,500 (Transfer Book "1", page 22).

In 1935, Dan L. Cookes establishes a funeral home in this large residence. D.L. Cookes, undertaker and embalmer, had been located a block to the south in the commercial building at 119 N. Main from 1919 until 1935. This move followed a trend in this period of utilizing residences as funeral homes, rather than commercial buildings. The newspaper noted in August 1935: "The furnishings of the Cookes funeral chapel were moved today from the location just north of the square on Main street to the new Cookes

Iowa Site Inventory Form
State Historic Preservation Office
Continuation Sheet

Site Number: 44-00259
Related District Number: 44-02280

Page 5

J.F. Sargent House / D.L. Cookes Funeral Home	Henry
Name of Property	County
213 N. Main St	Mount Pleasant
Address	City

funeral home at Main and Henry streets” (*The Mount Pleasant News*, August 8, 1935, page 6). Then, “New Cookes Funeral Home Open Saturday – The Cookes funeral home in the property familiarly known as the Worthington place on North Main street has invited friends to call...The structure has been completely remodeled and refinished...new flooring (has been) put in throughout the building, and a new garage built at the rear” (*The Mount Pleasant News*, August 16, 1935, page 1). The Bystander’s Notes observed in September 1935 that D.L. Cookes had removed and repaired the old Worthington home on N. Main into a very beautiful property on both the exterior and interior for use as a funeral home. The work was just being completed (“The Bystander’s Notes,” *Mt Pleasant News*, September 18, 1935, 2).

In May 1937, Dan Cookes was noted to be constructing a new addition to the funeral home, which he recently purchased and remodeled (“The Bystander’s Notes,” *Mt Pleasant News*, May 14, 1937, 2). The 1938 city directory list the D.L. Cookes Funeral Home operated at 215 N. Main St under the headings of funeral home, embalmer, mortician, undertaker, and ambulance service.

The 1942 Sanborn fire insurance map shows this dwelling is now used for an undertaking establishment, and it has been enlarged with a small one-story addition on the north side of the earlier rear addition. The address is 215 N Main. The main, two-story, brick section of the building is noted as 24’ in height, with 12’ ceilings on each floor. The 2-story, brick addition at the west is 20’ in height. A 1-story, brick addition has been added to the north of the rear addition, extending the building to W Henry. On the rear/west of the two-story rear addition, a 1-story, brick/tile garage has been added, large enough for 4 cars. A 1-story, frame garage is shown along the alley.

Mount Pleasant telephone directories from 1937 through 1950, show the D.L. Cookes Funeral Home operating at 215 N Main. They note offering undertaking and ambulance service. The residence of D.L. Cookes was located on the second story. Daniel L. Cookes died on May 8, 1948, at age 64.

On August 26, 1949, the estate of D.L. Cookes changed title of the property to Nellie R. Cookes, who then sells the lot to George A. Elliott and A.T. Lunning on August 1, 1950. On August 19, 1950, Alvern T. and G. Genevieve Lunning transfer the lot to George A. Elliott. On March 6, 1954, George A. and M. Gertrude Elliott return the property to Alvern T. and G. Genevieve Lunning (Transfer Book “2”, page 20).

Mount Pleasant city directories from 1951 through 1955, show the Cookes-Lunning Funeral Home, funeral services, operating at 215 N Main. They noted offering ambulance service any time. Al and Genevieve Lunning lived on the second story.

In 1955, Al Lunning sold the funeral home to M. Hall Weir of Mt. Pleasant. Hall operated the business as the Weir-Cookes Funeral Home until 1975. By 1957, the address has changed to 213 N Main, and the name of the business changes to the Weir-Cookes Funeral Home. M. Hall and Mary E. Weir lived on the second story through the 1960s, along with children Kathryn and Thomas. On 15 July 1964, Alvern T. and G. Genevieve Lunning, via warranty deed, sell the property to M. Hall and Mary S. Weir (Transfer Book “2”, page 20). In November 1963, a building permit was issued to M.H. Weir for a two-story frame addition on the south side of the rear section for overflow space on the first story and an additional room on the second story (City of Mt Pleasant building permits). The name of the funeral home remains the Weir-Cookes Funeral Home until 1975. They continue to offer ambulance service any time. M. Hall and Mary Weir continue to live on the second story.

Iowa Site Inventory Form
State Historic Preservation Office
Continuation Sheet

Site Number: 44-00259
Related District Number: 44-02280

Page 6

J.F. Sargent House / D.L. Cookes Funeral Home	Henry
Name of Property	County
213 N. Main St	Mount Pleasant
Address	City

In 1975, M. Hall Weir renamed it to the Weir Funeral Home. The 1981 city directory lists the Weir Funeral Home at 213 N. Main St. M. Hall Weir is the owner and funeral director, with Thomas H. Weir, manager. The Weirs continued to live on the second story. On January 6, 1984, Hall and Mary Weir sold the property as well to Thomas H. Weir (Transfer Book "3", page 19). Hall also sold the business to his son Tom in 1984. The 1986 city directory then lists Thomas H. and Cynthia Weir living on the second story, along with children Thomas and Andrea.

In 2001, Thomas H. Weir sold the business and the property to Mark and Linda Kimzey. While a student at Iowa Wesleyan College, Mark had worked at the funeral home for Hall and Tom.

This commercial building at 213 N Main is currently occupied in 2023 by Kimzey Funeral Home, a provider of funeral services. The business is operated by Mark Kimzey. The building remains owned by Mark and Linda Kimzey.

9. Major Bibliographical References

Biographical Review of Henry County, Iowa. Chicago, IL: Hobart Publishing Company, 1906.

Building and sign permits, City of Mount Pleasant, Iowa

City and telephone directories, Mt Pleasant:

Bowron, Watson. *Henry County Directory for 1859-60*. Burlington, IA: Watson Bowron, 1859.

Annawalt & Lawrence's Bi-ennial Mt Pleasant Directory. Burlington, IA: Hawk-Eye Steam Printing House, 1867.

Annewalt, E.H., compiler. *Mount Pleasant City Directory*. Burlington: Daily Gazette, 1870.

Mount Pleasant City Directory for 1893. Mt. Pleasant, IA: Francis D. Craig, 1893.

Mason, George T. *Directory of Henry County, Iowa, 1911-12*. Mt. Pleasant, IA: The News, 1911.

Mount Pleasant Telephone Company. Telephone directories issued in 1913, 1915, 1918, 1921, 1925, 1927, 1937, 1939, 1944, 1948, 1950, 1952.

Groce, W.H. *The City Directory of Mt. Pleasant, Iowa*. Mt Pleasant: Groce, 1938.

Johnson Publishing Co. *Mt Pleasant, Iowa*. City directories issued in 1955, 1957, 1960, 1964, 1966, 1968, 1970, 1873, 1976, 1981, 1986, 1993, 2001, 2011. Manitowoc, WI: Johnson Publishing Co.

Cornerstones. Mt Pleasant: Mt. Pleasant Beautiful Committee, 1991.

Henry County Bicentennial Commission (HCBC). *The History of Henry County*. Dallas, TX: National ShareGraphics, Inc., 1982.

Henry County Historical Society. Vertical files and albums in files at Mt Pleasant Public Library.

Henry County Heritage Trust. Collection of historic images, in files and posted in Facebook albums. Collection in former Saunders School, Mount Pleasant, Iowa.

Henry County Recorder's Office / Henry County Auditor's Office. Property records, transfer books, and deed records. Henry County Courthouse, Mt Pleasant, Iowa

Iowa Site Inventory Form
State Historic Preservation Office
Continuation Sheet

Site Number: 44-00259
Related District Number: 44-02280

Page 7

J.F. Sargent House / D.L. Cookes Funeral Home	Henry
Name of Property	County
213 N. Main St	Mount Pleasant
Address	City

History of Henry County, Iowa. Chicago: Western Historical Company, 1879.

Jaynes, Peter H., ed. *Highlights of Henry County History 1833-1976.* Burlington, IA: Doran & Ward Lithographing Co., 1977.

Koch, Augustus. *Birds-Eye View of the City of Mount Pleasant, Henry County, Iowa.* Chicago, IL: Merchants Lithographing Co, 1869. In collection of Henry County Heritage Trust and Mount Pleasant Public Library, Mount Pleasant, Iowa.

Mount Pleasant Beautiful. Mt Pleasant: Mt Pleasant News Company, 1909. Reprint issued in 1988.

Mount Pleasant, Iowa, Sesquicentennial, 1835-1985 (MPS). Mt Pleasant, IA: The Committee, 1985

Naumann, Molly Myers. *Architectural and Historical Resources of Mount Pleasant, IA.* National Register of Historic Places Multiple Documentation Form, May 1991. On file with the State Historic Preservation Office, Des Moines, IA.

Portrait and Biographical Album of Henry County, Iowa. Chicago: Acme Publishing Co., 1888.

Sanborn Map Company. *Mount Pleasant, Iowa.* Fire insurance maps for 1886, 1892, 1899, 1909, 1920, 1942. Library of Congress, Geography and Map Division, Sanborn Maps Collection.

Iowa Site Inventory Form
State Historic Preservation Office
Continuation Sheet

Site Number: 44-00259
 Related District Number: 44-02280

Page 8

J.F. Sargent House / D.L. Cookes Funeral Home
 Name of Property

Henry
 County

213 N. Main St
 Address

Mount Pleasant
 City

Location map



Iowa Site Inventory Form
State Historic Preservation Office
Continuation Sheet

Site Number: 44-00259
Related District Number: 44-02280

Page 9

J.F. Sargent House / D.L. Cookes Funeral Home

Henry

Name of Property

County

213 N. Main St

Mount Pleasant

Address

City

Building footprint

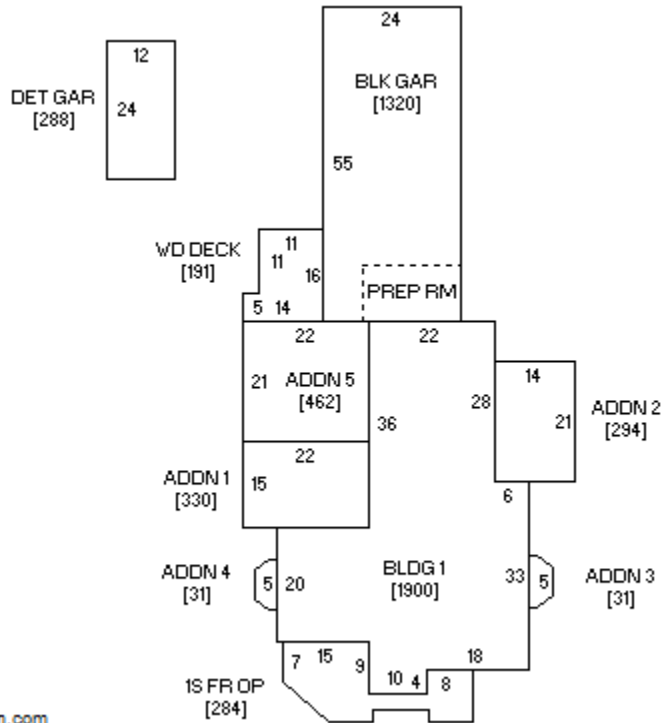

Sketch by www.camavision.com

Henry County Assessor (<https://beacon.schneidercorp.com>)

Iowa Site Inventory Form
State Historic Preservation Office
Continuation Sheet

Site Number: 44-00259
Related District Number: 44-02280

Page 10

J.F. Sargent House / D.L. Cookes Funeral Home
Name of Property

Henry
County

213 N. Main St
Address

Mount Pleasant
City

Historic images



Phone 360

COOKES
FUNERAL
HOME

Ambulance Service

215 North Main Street
MT. PLEASANT, IOWA

Ad in 1937 telephone directory

Iowa Site Inventory Form
State Historic Preservation Office
Continuation Sheet

Site Number: 44-00259
Related District Number: 44-02280

Page 11

J.F. Sargent House / D.L. Cookes Funeral Home
Name of Property

Henry
County

213 N. Main St
Address

Mount Pleasant
City



Funeral home on June 16, 1973 (HCHT Facebook album)

Iowa Site Inventory Form
State Historic Preservation Office
Continuation Sheet

Site Number: 44-00259
Related District Number: 44-02280

Page 12

J.F. Sargent House / D.L. Cookes Funeral Home
Name of Property

Henry
County

213 N. Main St
Address

Mount Pleasant
City



1990 survey photograph (Naumann 1991)

Iowa Site Inventory Form
State Historic Preservation Office
Continuation Sheet

Site Number: 44-00259
Related District Number: 44-02280

Page 13

J.F. Sargent House / D.L. Cookes Funeral Home
Name of Property

Henry
County

213 N. Main St
Address

Mount Pleasant
City

Digital photographs



Photograph 44-00259-001. East elevation, looking west (October 2023)

Iowa Site Inventory Form
State Historic Preservation Office
Continuation Sheet

Site Number: 44-00259
Related District Number: 44-02280

Page 14

J.F. Sargent House / D.L. Cookes Funeral Home
Name of Property

Henry
County

213 N. Main St
Address

Mount Pleasant
City



Photograph 44-00259-002. North elevation, looking southwest (October 2023)

Iowa Site Inventory Form
State Historic Preservation Office
Continuation Sheet

Site Number: 44-00259
Related District Number: 44-02280

Page 15

J.F. Sargent House / D.L. Cookes Funeral Home
Name of Property

Henry
County

213 N. Main St
Address

Mount Pleasant
City



Photograph 44-00259-003. South elevation, looking northwest (October 2023)

Iowa Site Inventory Form
State Historic Preservation Office
Continuation Sheet

Site Number: 44-00259
Related District Number: 44-02280

Page 16

J.F. Sargent House / D.L. Cookes Funeral Home
Name of Property

Henry
County

213 N. Main St
Address

Mount Pleasant
City



Photograph 44-00259-004. South elevation, looking northeast (October 2023)

Iowa Site Inventory Form
State Historic Preservation Office
Continuation Sheet

Site Number: 44-00259
Related District Number: 44-02280

Page 17

J.F. Sargent House / D.L. Cookes Funeral Home

Name of Property

Henry

County

213 N. Main St

Address

Mount Pleasant

City



Photograph 44-00259-005. North and west elevations, looking southeast (October 2023)

Iowa Site Inventory Form
State Historic Preservation Office
Continuation Sheet

Site Number: 44-00259
Related District Number: 44-02280

Page 18

J.F. Sargent House / D.L. Cookes Funeral Home
Name of Property

Henry
County

213 N. Main St
Address

Mount Pleasant
City



Photograph 44-00259-006. West elevation, looking east (October 2023)

Iowa Site Inventory Form
State Historic Preservation Office
Continuation Sheet

Site Number: 44-00259
Related District Number: 44-02280

Page 19

J.F. Sargent House / D.L. Cookes Funeral Home
Name of Property

Henry
County

213 N. Main St
Address

Mount Pleasant
City



Photograph 44-00259-007. West elevation of garage, looking east (October 2023)